



*Tender Notice No. NHSRCL/Vadodara/Plumbing Utilities/2019-20/03
Appointment of consultant for specialized work of Consultancy for shifting, temporary operation & reinstating various pipelines
between Jetalpur Bridge (Ch396.582) to Pandya Bridge (Ch398.430) on proposed High-Speed Railway alignment in Vadodara
Station area.*

**Tender No. NHSRCL/VADODARA/PLUMBING UTILITIES/
2019-20/03**

Bidding documents

For

**Appointment of consultant for specialized work of Consultancy for
shifting, temporary operation & reinstating various pipelines
between Jetalpur Bridge (Ch396.582) to Pandya Bridge(Ch398.430)
on proposed High Speed Railway alignment in Vadodara Station
area.**

**National High Speed Rail Corporation Limited
3rd Floor , Productivity House, Productivity Road,Alkapuri
Vadodara -390007**

*Dy. Chief Project Manager-Civil
National High Speed Rail Corporation Ltd.
Vadodara*

Seal & Signature of Tenderer

1

NHSRCL-Vadodara



Tender Notice No. NHSRCL/Vadodara/Plumbing Utilities/2019-20/03

Appointment of consultant for specialized work of Consultancy for shifting, temporary operation & reinstating various pipelines between Jetalpur Bridge (Ch396.582) to Pandya Bridge (Ch398.430) on proposed High-Speed Railway alignment in Vadodara Station area.

TENDER DOCUMENTS

Name of the work: Appointment of consultant for specialized work of Consultancy for shifting, temporary operation & reinstating various pipelines between Jetalpur Bridge (Ch396.582) to Pandya Bridge (Ch398.430) on proposed High-Speed Railway alignment in Vadodara Station area.

CONTENTS

Part	Description	Page
Part I	TENDER NOTICE	3-5
Part II	TERMS OF REFERENCE	6-18
Part III	FORMAT FOR SUBMISSION	16-18
Part IV	ESTIMATED COST OF WORKS	19-19
Part V	TENDER DRAWINGS	19-19 with Annexure(s)
Part VI	OFFER SHEET	20-20
Part VII	DECLARATION	21-21

Dy. Chief Project Manager-Civil
उप मुख्य परियोजना प्रबंधक (सिविल)
National High Speed Rail Corporation Ltd.
राजस्थान
वडोदरा / Vadodara

Seal & Signature of Tenderer

2

NHSRCL-Vadodara



Tender Notice No. NHSRCL/Vadodara/Plumbing Utilities/2019-20/03

Appointment of consultant for specialized work of Consultancy for shifting, temporary operation & reinstating various pipelines between Jetalpur Bridge (Ch396.582) to Pandya Bridge (Ch398.430) on proposed High-Speed Railway alignment in Vadodara Station area.

Part I

TENDER NOTICE

National High-Speed Rail Corporation Limited, Vadodara Division invites tender from well-established, reputed and eligible agencies For Appointment of consultant for specialized work of Consultancy for shifting, temporary operation & reinstating various pipelines between Jetalpur Bridge (Ch396.582) to Pandya Bridge (Ch398.430) on proposed High-Speed Railway alignment in Vadodara Station area. The work is specialized work of Detailed Design scheme preparation for Shifting(temporarily, permanently)/Diverting existing underground plumbing utilities including preparation of detailed cost estimate, BOQ, Specifications, GFC drawings, approvals from various stakeholders, supervision of works etc. complete.

1.0 Chief Project Manager (Civil), National High Speed Rail Corporation Limited, 3rd Floor, Productivity House, Productivity Road, Alkapuri, Vadodara -390007 invites sealed tender in prescribed forms for the under mentioned work.

1	Name of work	Vadodara Division: – Appointment of consultant for specialized work of Consultancy for shifting, temporary operation & reinstating various pipelines between Jetalpur Bridge (Ch396.582) to Pandya Bridge (Ch398.430) on proposed High Speed Railway alignment in Vadodara Station area.
2	Estimated Cost	Rs. 43,00,000.00 (Rs. Fourty three lacs Only) excluding GST
3	Earnest Money Deposit	Rs. 86,000.00(Rs. Eighty six thousand only)
4	Tender Fee	Rs. 3540 (inclusive of GST@18%)
5	Validity of offer	90 Days
6	Type of tender	Open tender
7	Tender closing date	29.04.2019 @ 15:00 hrs
8	Tender opening date	29.04.2019 @ 15:30 hrs
9	Place of submission and opening of tender	Office of Chief Project Manager(Civil), 3rd Floor, Productivity House, Productivity Road, Alkapuri, Vadodara -390007

Information for Tenderers-

1. The cost of Tender Document is **Rs. 3,540 /- (Three Thousand five hundred & fourty only)** inclusive of GST@18%. The cost of tender document should be submitted along with tender form in the form of Pay Order/Demand Draft payable in favour of M/s National High Speed Rail Corporation Limited at New Delhi. GSTIN certificate shall be attached by the tenderer. Tender form can be obtained from the office of Chief Project Manager (Civil) between 10:30 hrs to 17:00 hrs. on all working days from **05.04.2019**. *The tender documents will be available from 05.04.19 for download on www.nhsrcl.in under the link*

Seal & Signature of Tenderer

3

By, Chief Project Manager-Civil
National High Speed Rail Corporation Ltd.
राष्ट्रीय उच्च गति रेल निगम लिमिटेड
वडोदरा / Vadodara



Tender Notice No. NHSRCL/Vadodara/Plumbing Utilities/2019-20/03

Appointment of consultant for specialized work of Consultancy for shifting, temporary operation & reinstating various pipelines between Jetalpur Bridge (Ch396.582) to Pandya Bridge (Ch398.430) on proposed High-Speed Railway alignment in Vadodara Station area.

“Tenders – →Active Tenders”.

- 1.1 Address for tender documents collection and submission-
Office of Chief Project Manager (Civil),
3rd Floor, Productivity House, Productivity Road, Alkapuri, Vadodara -390007
2. Completed original tender documents sealed in an envelope super-scribing the name of work; name and address of the bidder, shall be submitted at NHSRCL's office at address in Para 1.1 above on or before 15:00 hrs. on 29.04.2019. Tender duly sealed in the prescribed manner above can also be sent through Registered Post/Courier so as to reach at the office address given in para 1.1 above **not later than 15.00 hrs. on 29.04. 2019.** Any tender received later than tender closing time at NHSRCL's office at Vadodara shall be rejected/ unaccepted and returned to the bidder unopened. Earnest Money Deposit may be submitted in the form of Pay Order/Demand Draft/Fixed Deposit Receipt payable in favour of M/s National High-Speed Rail Corporation Limited at New Delhi. Tender received without Earnest Money Deposit shall be summarily rejected.
3. Tender shall be submitted in accordance with the terms of the terms of reference in the attachment hereto, which forms part of this Notice Inviting Tender.
4. Interested eligible bidders who have purchased/ downloaded the tender document are invited to attend a Pre-Bid meeting to be held on **16.04.2019 at the office address as per para 1.1 above at 15:00 hrs.** Participation in this Pre-Bid meeting is not mandatory.
5. National High-Speed Rail Corporation Limited reserves the right to cancel the tender before submission/opening of tender, postpone the tender submission/opening date and to accept /reject any or all tenders without assigning any reasons thereof.
6. Tenderer may note that they are liable to be disqualified at any time during the tendering process in case any of the information furnished by them is not found to be true. The decision of NHSRCL in this regard shall be final and binding.
7. The validity of the offer shall be 90 days from the date of opening of the tender.
8. The bidder is required to have experience of having executed similar works as detailed in the bidding document.
9. SCOPE OF WORKS: Scope of works includes but not limited to:
 - a. Detailed design scheme preparation for shifting, diverting, removing existing plumbing utilities (open, underground & on ground) at subject location between Jetalpur Bridge(Ch396.582) to Pandya Bridge(Ch398.430) related to drainage lines (gravity & pressure), waste water line, storm water line, water line, relocation of auxiliary pumping station etc. including submission, follow-up and approval of scheme(s) from Vadodara Municipal Corporation(VMC), Traffic police, Railways, other concerned authority/agency etc.& fulfilling all the statutory requirements.

Seal & Signature of Tenderer

Dy. Chief Project Manager-Civil
4
उप मुख्य परियोजना प्रबंधक-**NHSRCL-Vadodara**
National High Speed Rail Corporation Ltd.
राष्ट्रीय उच्च गति रेल कॉर्पोरेशन लिमिटेड
वडावरा / Vadodara



Tender Notice No. NHSRCL/Vadodara/Plumbing Utilities/2019-20/03

Appointment of consultant for specialized work of Consultancy for shifting, temporary operation & reinstating various pipelines between Jetalpur Bridge (Ch396.582) to Pandya Bridge (Ch398.430) on proposed High-Speed Railway alignment in Vadodara Station area.

- b. Preparation of detailed cost estimate as per prevalent local Schedule of Rates, Bill of quantities, technical specifications for each type of lines including pumps etc. for shifting/diverting sewage, water etc. as required as infringing in foundation works of HSR Corridor from Jetalpur bridge to Pandya Bridge including supervision of execution of temporary & permanent works for complete period of construction by agency as deployed by NHSRCL.
- c. Preparation of contract package & selection of contractor for execution through tender to be deployed by NHSRCL.
- d. Design & supervision of Reinstating all the plumbing utilities to its original/designed new location after construction of foundations of HSR corridor by agency to be deployed by NHSRCL up to commissioning approval by the regulatory authority/ agency of city is included the scope of work.
- e. Preparation of GFC drawings, method statement for diversion, shifting for each plumbing utility (temporary/permanent; gravity, pressure lines etc.) i.e. waste water, storm water, drinking water including detailed sections/slopes etc. complete at various locations as required for execution of works.
- f. Existing plumbing utilities to be integrated temporarily or permanently such that all lines (gravity & pressure), Pumping stations etc. are working normally during construction, monsoon etc.
- g. Brief detail of tentative existing charted plumbing utilities at locations of foundations of HSR corridor are detailed below:
 - i. Water pipe line of dia. 150mm,250mm & 350mm at approx. 1.5m depth
 - ii. Storm water line of dia. 300mm at approx. 2.43 m depth
 - iii. Waste water line of dia. 450mm at depth of approx. 3.35 m with manholes.
- h. The above sizes & locations are tentative as per details collected.
- i. Any other plumbing utility works required in the said location so as to execute & complete the work as detailed above.
- j. Any and all other works as indicated and considered necessary for execution of this work whether or not specifically mentioned or called for.

End of Part I

Dy. Chief Project Manager-Civil
उप मुख्य परियोजना प्रबंधक-सिविल
National High Speed Rail Corporation Ltd.
राष्ट्रीय उच्च गति रेल निगम लिमिटेड
वडोदरा / Vadodara



Tender Notice No. NHSRCL/Vadodara/Plumbing Utilities/2019-20/03

Appointment of consultant for specialized work of Consultancy for shifting, temporary operation & reinstating various pipelines between Jetalpur Bridge (Ch396.582) to Pandya Bridge (Ch398.430) on proposed High-Speed Railway alignment in Vadodara Station area.

Part II

TERMS OF REFERENCE (TOR)

1. Scope of works :-

Scope of works includes but not limited to:

1. Detailed design scheme preparation for shifting, diverting, removing existing plumbing utilities (open, underground & on ground) at subject location between Jetalpur Bridge(Ch396.582) to Pandya Bridge(Ch398.430)related to drainage lines (gravity & pressure), waste water line, storm water line, water line, relocation of auxiliary pumping station etc. including submission, follow-up and approval of scheme(s) from Vadodara Municipal Corporation(VMC), Traffic police, Railways, other concerned authority/agency etc.& fulfilling all the statutory requirements along with coordination with the approving and concerned statutory authorities.
2. Preparation of detailed cost estimate as per prevalent local Schedule of Rates, Bill of quantities, technical specifications for each type of lines including pumps etc. for shifting/diverting sewage, water etc. as required as infringing in foundation works of HSR Corridor (superstructure & superstructure works) from Jetalpur bridge to Pandya Bridge including supervision of execution of temporary & permanent works for complete period of construction by agency as deployed by NHSRCL.
3. Preparation of contract package & selection of contractor for execution through tender to be deployed by NHSRCL.
4. Design & supervision of Reinstating all the plumbing utilities to its original/designed new location after construction of foundations of HSR corridor by agency to be deployed by NHSRCL.
5. Preparation of GFC drawings, methodology for diversion, shifting for each plumbing utility (temporary/permanent; gravity, pressure lines etc.) i.e. waste water, storm water, drinking water including detailed sections/slopes etc. complete at various locations as required for execution of works.
6. Existing plumbing utilities to be integrated temporarily or permanently such that all lines (gravity & pressure), Pumping stations etc. are working normally during construction, monsoon etc.
7. Brief detail of tentative existing plumbing utilities at locations of foundations of HSR corridor are detailed below:
 - a. Water pipe line of dia 150mm,250mm & 350mm at approx. 1.5m depth
 - b. Storm water line of dia 300mm at approx. 2.43 m depth
 - c. Waste water line of dia 450mm at depth of approx. 3.35 m with manholes.
8. The above sizes & locations are tentative as per details collected.
9. Any and all other works as indicated and considered necessary for execution of this work whether or not specifically mentioned or called for.
10. A. Preparation of Detailed Scheme- The consultant shall prepare a detailed scheme highlighting the following:

Seal & Signature of Tenderer

Dy. Chief Project Manager-Civil
उप मुख्य परियोजना प्रबंधक-सिविल
National High Speed Rail Corporation Ltd.
राष्ट्रीय उच्च गति रेल कॉर्पोरेशन लिमिटेड
वडोदरा / Vadodara
NHSRCL-Vadodara



Tender Notice No. NHSRCL/Vadodara/Plumbing Utilities/2019-20/03

Appointment of consultant for specialized work of Consultancy for shifting, temporary operation & reinstating various pipelines between Jetalpur Bridge (Ch396.582) to Pandya Bridge (Ch398.430) on proposed High-Speed Railway alignment in Vadodara Station area.

- a. Detailed layout of existing network, Planned temporary and permanently shifting network of drainage, sewage, drinking water, storm water etc. including others related to plumbing (charted & uncharted), if any, of complete location as detailed above on drawings.
- b. Detailed Report of site survey and record of levels/ level charts, services plan, sections of manholes, chambers and all plumbing utilities etc. of existing network & planned temporary & permanently shifting network of all types of plumbing utilities (charted & uncharted).
- c. Scheme for operation and maintenance of existing/diverted (temporarily or permanently) network of various plumbing utilities during the construction period of HSR works (substructure & superstructure) at the subject location as well as after completion of HSR works.

10. B. Technical parameters must cover the followings:

- a. Detailed specification of complete electro-mechanical equipment, machineries, utility pipes of various sizes etc.
- b. Bills of quantity duly priced. All estimates shall be prepared on the basis of State schedule of rates, norms wherever applicable & on the basis of market rates analysis where PWD rates/ State Schedule of rates etc. are not applicable. These estimates shall be comprehensive and should include all items of subject work. Detailed analysis of the items not included in state PWD rates/ Schedule of rates shall have to be submitted.
- c. Detailed electro-mechanical Drawings, Design calculations for all the components of individual utilities. Detailed technical specification for all the non-scheduled items proposed in the schemes including getting the approval of scheme.
- d. Any other drawings, information, details required for completion & execution of subject works but not mentioned above.
- e. All investigation, site survey, collection of required data from the site from the concerned authorities/related stakeholders, as built drawings etc. of existing site location
- f. Adoption of innovative approaches and adaption of proven and appropriate technologies.

11. Location of works -: New High-Speed Railway corridor as mentioned under -:
Between Jetalpur Bridge (Ch396.582) to Pandya Bridge (Ch398.430) including Vadodara station area.

12. Tentative drawings of the above-mentioned location's plumbing utilities are enclosed with the tender. These drawings are indicative only for references and the tenderers are advised to visit the locations for proper assessment before submitting the tender offer.

13. Modus operandi -: It is planned that the existing LIIVE plumbing utilities are to be diverted & or shifted (temporarily or permanently) during the construction of HSR corridor (superstructure & superstructure works) so that construction of HSR corridor can be done at designated location & after construction of HSR corridor all the utilities are reinstated at their original/ designed new location so that flow of sewage, drainage, drinking water & storm water etc by gravity or pressure in designated location is not affected in any way in all seasons at all times.

Seal & Signature of Tenderer

Dy. Chief Project Manager-Civil
उप मुख्य परियोजना प्रबंधक-सिविल
7 National High Speed Rail Corporation Ltd.
राष्ट्रीय उच्च गति रेल निगम लिमिटेड
वडादरा / Vadodara
NHSRCL-Vadodara



Tender Notice No. NHSRCL/Vadodara/Plumbing Utilities/2019-20/03

Appointment of consultant for specialized work of Consultancy for shifting, temporary operation & reinstating various pipelines between Jetalpur Bridge (Ch396.582) to Pandya Bridge (Ch398.430) on proposed High-Speed Railway alignment in Vadodara Station area.

13. Key Task & responsibility:

- a. Successful tenderer shall look after all the existing utilities in the designated locations and will accordingly plan for shifting/diverting of same so that construction of HSR corridor can be done.
- b. It will be the responsibility of the bidder to ensure that the design is such that flow of existing drainage, sewerage, water & storm water line will be maintained by gravity or pressure during & after construction of HSR Corridor at designated location.
- c. Successful tenderer shall execute the work in time as per work order in full coordination with NHSRCL.
- d. The successful tenderer will be solely responsible for complete design scheme preparation including
- e. All governance, monitoring and reporting aspect of this assignment at will be controlled by the concerned NHSRCL officials. The consultant shall interact with NHSRCL regularly & will submit the monthly progress report with snaps etc in a specified format as approved by NHSRCL.

2 TIME & PAYMENT SCHEDULE: The detailed time schedule & payment schedule is as below:

S. No	Description of work	Time Schedule	Payment Schedule
a	Complete survey work including taking levels etc & Submission of draft Scheme	Within 45 days	15% of consultancy fees
b	Submission of final Scheme complete in all respects including designs/ drawings / specifications & cost estimates of all the components of the scheme etc.	Within 30 days after vetting of draft Scheme BY NHSRCL	10% of consultancy fees
c	Getting approvals of Final Scheme from concerned authorities like VMC, Traffic, Railways etc. as applicable for said location as the cases may be (Authorities to be recommended by NHSRCL)	As per the schedule decided by the NHSRCL (payment to be made after approval is received)	10% of consultancy fees
d	After preparation of tender document, publication, evaluation of technical and financial bids and allotment of work to successful bidder for execution of works	Within 45 days after Final Scheme approval	10% of consultancy fees
e	From the date of start of execution of works deployment of resources by bidder (as per item No. 4) as per the satisfaction of NHSRCL the payment shall be made at the end of each quarter @ 5%	30 Months or 10 Quarters @ 5% per quarter	50% of consultancy fees
f	After successful completion & handing over of project	-	5% plus Security deposit as deducted from each bill @ 10%

Seal & Signature of Tenderer

8

NHSRCL-Vadodara
Dy. Chief Project Manager-Civil
 उप मुख्य परियोजना प्रबंधक-सिविल
 National High Speed Rail Corporation Ltd.
 राष्ट्रीय उच्च गति रेल निगम लिमिटेड
 वडोदरा / Vadodara



Tender Notice No. NHSRCL/Vadodara/Plumbing Utilities/2019-20/03

Appointment of consultant for specialized work of Consultancy for shifting, temporary operation & reinstating various pipelines between Jetalpur Bridge (Ch396.582) to Pandya Bridge (Ch398.430) on proposed High-Speed Railway alignment in Vadodara Station area.

Note:

1. In case NHSRCL want the consultancy beyond 3 years the charges shall be paid @ 3% per quarter or as per the mutual agreed rates
2. Goods & services tax will be paid extra on submission of documentary evidence of same.
3. All schemes, Reports, BOQ , tender documents, Other documents etc are required to be submitted in soft as well as two copies in hard to NHSRCL.

3 OTHER TERMS AND CONDITIONS

1. If any new component is to be added to the scheme, the consultant shall collect all the data, including surveys, investigations required for the planning & designing of additional component in the scheme. Nothing extra shall be payable on this account.
2. Preparation and submission of 4sets of detailed designs and calculations. BOQ, construction drawings of all the components of the schemes as per requirement.
3. List of spares of all the equipment's to be installed at site.
4. All visits performed by the consultant in connection with planning, designing, detailing obtaining approval from clients as applicable including conducting visits to the officers of approving authorities, sites, office of NHSRCL. Nothing extra shall be payable on this account.
5. All surveys, field investigation from any specialised equipment's as directed by NHSRCL, data collections, site visits, sample collections, sample testing (with due information to NHSRCL before carrying out the activity) etc. required for the Preparation & finalisation of scheme are in scope of work of consultant and nothing extra shall be payable on this account.
6. The consultant shall provide 4 No. hard copies and four No. soft copies in original format for checking by NHSRCL of following documents: -
 - i. Detailed project Scheme, existing as well as proposed temporary & final diversion/shifting scheme during & after construction of HSR works with all drawings in color.
 - ii. Detailed design calculations of structural, electro mechanical equipment's, Pipes and other services with slope etc. complete including drawings incorporating subsequent modifications.
 - iii. All working drawings of total components (good for construction drawings).
 - iv. Detailed estimated and rate analysis of all works.
 - v. Completion drawings/As built drawings and detailed documents.
7. The sound and correct design, keeping in view the respective nature of sewerage, storm water, drinking water etc. and climatic conditions, monsoon & construction stage of HSR etc., Consultant shall be duly responsible for evolving safe, economic, technically feasible and practical scheme which must be vetted by all stakeholders.
8. The consultancy works may be terminated at any time by open 30 days' notice in writing being given to consultants, if the consultant's work is not found to be satisfactory according to the

Seal & Signature of Tenderer

9

NHSRCL-Vadodara
Dy. Chief Project Manager-Civil
उप मुख्य परियोजना प्रबंधक-सिविल
National High Speed Rail Corporation Ltd.
राष्ट्रीय उच्च गति रेल निगम लिमिटेड
वडोदरा / Vadodara



Tender Notice No. NHSRCL/Vadodara/Plumbing Utilities/2019-20/03

Appointment of consultant for specialized work of Consultancy for shifting, temporary operation & reinstating various pipelines between Jetalpur Bridge (Ch396.582) to Pandya Bridge (Ch398.430) on proposed High-Speed Railway alignment in Vadodara Station area.

terms of the agreement. In case the agreement is terminated on account of consultant's work not being satisfactory, Department will get the work done through alternate means at the risk and cost of the consultant.

9. In case the consultant fails to complete the work within the contract period or extended period as above owing to reasons attributable to consultant, liquidated damages @1% per week of the total fees subject to a maximum of 10% of the total fees payable shall be levied on the consultant. Department shall be entitled to deduct such damages from the dues that may be payable to the consultant. If the work is held up at site due to no-availability of drawings/specifications/other details, penalty, proportionate to the value of the work which is held up, shall be imposed on consultant.

10. The Design should be strictly as per the standard guidelines as per utility owing agencies and as per the direction (if any) suggested by NHSRCL from time to time.

11. Vetting of Design from the competent authority as designated by the NHSRCL is the responsibility of consultant. Nothing extra shall be paid for the same.

12. Soft copy in original format need to be submitted as and when asked by any stakeholders.

13. The consultant will be required to establish an office in Vadodara with dedicated experts as mentioned below for 3 years w.e.f date of allotment of execution of the project. The manpower to be deployed is as under

S.No	Position	Nos	Qualification/ Experience
1	Team Leader	1	M.Tech (Civil), specialization in Public Health Engineering with min. 15 years of relevant experience.
2	Construction Manager	1	B.Tech (Civil) specialization in Sewerage & Drainage with min. 12 years of relevant experience OR Diploma Civil with min. 15 years of relevant experience
3	Site Engineer	5	B.Tech (Civil) with min. 5 years of relevant experience OR Diploma Civil with min. 08 years of relevant experience

4 Responsibility for accuracy of works

The consultant shall be responsible for the accuracy of the data collected and the designs, drawings, quantities and estimates prepared by him as part of the project. He shall indemnify client against any inaccuracy in the work, which might surface out at the time of ground implementation of the project, in Such an eventuality the consultant will be responsible to correctly modify the drawings including the re investigation etc., as required.

5 Tax and other dues:

The consultant and their personnel shall pay the taxes, duties fees, levies, other Impositions levied under the standings laws during life of the contract.

Seal & Signature of Tenderer

10

Dy. Chief Project Manager, Challa
NHSRCL Vadodara
उप मुख्य परियोजना प्रबंधक-सिविल
National High Speed Rail Corporation Ltd.
राष्ट्रीय उच्च गति रेल कॉर्पोरेशन लिमिटेड
वडोदरा / Vadodara



Tender Notice No. NHSRCL/Vadodara/Plumbing Utilities/2019-20/03

Appointment of consultant for specialized work of Consultancy for shifting, temporary operation & reinstating various pipelines between Jetalpur Bridge (Ch396.582) to Pandya Bridge (Ch398.430) on proposed High-Speed Railway alignment in Vadodara Station area.

6 With holding and lien of payment.

Whether any claim or claims for payment of money arises out of or under the contract against the consultant, the NHSRCL shall be entitled to withhold and also to have a lien to retain in whole or in part, the security deposit, performance guarantee (if any) and or to withhold and have lien to retain in part or full the payments due to the consultant, are as to cover the claimed amount till the claim arising out of or under the contract is determined by the competent court.

7 Duration of works -: The Detailed design preparation has to be prepared as per the timelines mentioned in section "Time Schedule" and the duration of preparation of scheme, its approval & execution as per approved scheme with technical supervision is for 3 years from date of allotment.

8 Eligibility Criteria:

- a. The consultant must be empanelled for Design of Sewerage & Drainage Systems with Ministry of Urban Development Department, Govt. of India or with any other Ministry at the level of Govt. of India, State Govt., PWD, MES, Semi Government & other Corporations/Government Boards for Sewerage & Drainage Systems Design. Copy of Certificate to this effect may be enclosed
- b. The consultant /Firm shall have average annual financial Turnover of Rs. 100 lakhs (Rupees One Crore) every year for the last three financial years (2015-16, 2016-17&2017-18). Audited financial statements for last three years should be submitted along with the technical proposal. In case segment-wise result is not mentioned in the audited financial statement, a certificate to this effect may be enclosed from Agency's Chartered Accountant.
- c. The agency must have PAN, GST registration under applicable laws and should submit copies of the same.
- d. The agency must not have been debarred / blacklisted by any Govt. sector/PSUs/bilateral and multilateral agency for the service, ever in the past (Affidavit by the Notary of the same to be submitted by the Agency).
- e. The consultant must have completed minimum five , similar kind of works during the last ten years ending last day of month previous to the one in which applications are invited should be either of the following:
 - I. Three similar completed works costing not less than the amount equal to 40% of estimated cost.
 - II. Two similar completed works costing not less than the amount equal to 50% of estimated cost
 - III. One similar completed works costing not less than the amount equal to 80% of estimated cost

"Similar works is defined as the works related to design and development of municipal, city drainage, sewerage, storm water plumbing utilities system etc. complete including design development for shifting, diverting live running plumbing & sewerage lines of corporations, Govt./Semi Govt. institutions temporarily or permanently."

Seal & Signature of Tenderer

11

NHSRCL-Vadodara
Dy. Chief Project Manager-Civil
उप मुख्य प्रियोजना प्रबंधक-सिविल
National High Speed Rail Corporation Ltd.
राष्ट्रीय उच्च गति रेल प्रणाली लिमिटेड
वडोदरा / Vadodara



Tender Notice No. NHSRCL/Vadodara/Plumbing Utilities/2019-20/03

Appointment of consultant for specialized work of Consultancy for shifting, temporary operation & reinstating various pipelines between Jetalpur Bridge (Ch396.582).to Pandya Bridge (Ch398.430) on proposed High-Speed Railway alignment in Vadodara Station area.

- 9 Site Mobilization -: The successful tenderer should ensure that the work begins within 15 days from the date of issue of letter of acceptance.
- 10 The successful tenderer should work out in detail with NHSRCL officials regarding the planning of utility diversion/shifting scheme.
- 11 NHSRCL reserves the right to award tender to one or more than one bidder in part or full, as and when felt necessary, to any other Technically Qualified Bidder Agency without assigning any reason, at the same rate, terms & conditions to which the tenderer shall not be entitled to any compensation or consideration in any such events.
- 12 Earnest money deposit -: The agency shall furnish an Earnest Money Deposit (EMD) of INR. Rs. 86,000/- (Eighty-six thousand only) by crossed Demand Draft/Banker's Cheque/Fixed Deposit Receipts drawn by State Bank of India or any nationalized bank or Schedule Bank of India in favor of NATIONAL HIGH-SPEED RAIL CORPORATION LIMITED, Payable at New Delhi. Please note that no interest is payable on EMD so long retained in NHSRCL and Fixed Deposit Receipt should be from Scheduled Bank endorsed in the favor of client/Employer i.e. NATIONAL HIGH-SPEED RAIL CORPORATION LIMITED, Payable at New Delhi. Bid Received Without Earnest Money Shall Be Summarily rejected.
- 13 The tenderer should sign and affix his/his firm's stamp at each page of the tender and all its Annexure as the acceptance of the offer by the tenderer will be deemed as a contract and no separate formal contract will be drawn.
- 14 The said Earnest Money Deposit will not bear any interest and the earnest money of unsuccessful tenderer would be returned without any interest after finalization of the contract.
- 15 Performance Guarantee (P.G.)
 - a) On acceptance of tender the successful tenderer shall have to submit performance guarantee amounting to 5% of the contract value in any one of the form of irrevocable Bank Guarantee or FDR from Nationalized or scheduled bank in favor of NATIONAL HIGH-SPEED RAIL CORPORATION LIMITED. The Performance Guarantee shall be submitted within 30 (thirty) days from the date of issue of Letter of Acceptance (LOA). Extension of time for submission of PG beyond 30 (thirty) days and up to 60 days from the date of issue of LOA may be given by the Authority who is competent to sign the contract agreement. However, a penal interest of 15% per annum shall be charged for the delay beyond 30 (thirty) days, i.e. from 31st day after the date of issue of LOA.
 - b) This Guarantee shall be initially valid up to the stipulated date of completion plus 60 days beyond that. In case, the time limit for completion of work gets extended, the bidder shall give the validity of Performance Guarantee extended to cover such extended time for completion of work plus 60 days.

Seal & Signature of Tenderer

12

NHSRCL-Vadodara
Dy. Chief Project Manager-Civil
उप मुख्य परियोजना प्रबंधक-सिविल
National High Speed Rail Corporation Ltd.
राष्ट्रीय उच्च गति रेल प्रणाली लिमिटेड
वडोदरा / Vadodara



Tender Notice No. NHSRCL/Vadodara/Plumbing Utilities/2019-20/03

Appointment of consultant for specialized work of Consultancy for shifting, temporary operation & reinstating various pipelines between Jetalpur Bridge (Ch396.582) to Pandya Bridge (Ch398.430) on proposed High-Speed Railway alignment in Vadodara Station area.

- c) The Performance Guarantee (PG) shall be released after the physical completion of the work based on the "Completion Certificate" issued by the competent authority stating that the contractor as engaged by NHSRCL has completed the work in all respect satisfactorily. The security deposit, however, shall be released only after passing the final bill based on "No Claim Certificate".
- d) Wherever the contract is rescinded, the security deposit shall be forfeited and the Performance Guarantee shall be encashed and the balance work shall be got done independently without risk and cost of the failed bidder, the failed agency shall be debarred from participating in the tender for executing the balance work. If the failed agency is JV or a partnership firm, then every member/partner of such a firm shall be debarred from the participating in the tender for the balance work either in his/her individual capacity or as a partner of any other JV/partnership firm.
- e) The NHSRCL shall not make a claim under the Performance Guarantee except for amount to which the NHSRCL is entitled under the contract (not withstanding and /or without to any other provisions in the contract agreement) in the event of: -
- (i) Failure by the bidder to extend the validity of the Performance Guarantee as describe herein above, in which event the engineer may claim the full amount of the Performance Guarantee.
- (ii) Failure by the bidder to pay NHSRCL any amount due, either as agreed by the bidder or determined under any of the Clauses/Conditions of the agreement, within 30 days of the service of the notice to this effect by Engineer.
- (iii) The contract being determined or rescinded under provision of this contract, the Performance Guarantee shall be forfeited in full and shall be absolutely at the disposal of the NHSRCL.
- 16 All entries in the tender should be legible and filled clearly. If the space provided for furnishing the information is insufficient, a separate sheet duly signed by the authorized signatory may be scanned and uploaded. No correction either in the bid document.
- 17 In case of partnership firms, a copy of the partnership agreement, or general power of attorney duly attested by-Notary Public should be furnished on stamp paper duly sworn in and affirmed by all the partners admitting the execution of the partnership agreement or the general power of the attorney, which may be scanned and uploaded along with the tender documents. The attested copy of the Certificate of Registration of firm and the names of the authorized partner to interact with NHSRCL should also be scanned and uploaded along with the tender documents.
- 18 The bidding firm has to give a self-certificate to the effect that it has not been blacklisted by any Central Ministry/ Department/ PSUs or any other Government institutions. The certificate has to be submitted along with the tender documents. If it is subsequently established or found that the bidding firm has given any false information or facts or has suppressed facts or manipulated the documents,

Seal & Signature of Tenderer

13

Dy. Chief Project Manager
उप मुख्य परियोजना प्रबंधक-सिविल
National High Speed Rail Corporation Ltd.
राष्ट्रीय उच्च गति रेल कॉर्पोरेशन लिमिटेड
वडाદરા / Vadodara



Tender Notice No. NHSRCL/Vadodara/Plumbing Utilities/2019-20/03

Appointment of consultant for specialized work of Consultancy for shifting, temporary operation & reinstating various pipelines between Jetalpur Bridge (Ch396.582) to Pandya Bridge (Ch398.430) on proposed High-Speed Railway alignment in Vadodara Station area.

etc., the Earnest Money Deposit or the Performance Deposit, as the case may be, will be forfeited and no excuse what so ever will be entertained there for.

19 No bidding firm will be allowed to withdraw its bids after tender offers have been opened. If any firm intends to withdraw after opening of tender offer, its EMD will be forfeited.

20 Opening of Tender: The tenderer is at liberty either himself or authorize not more than one representative to be present at the opening of the tender. The representative attending the opening of the tender on behalf of the tenderer should bring with him a letter of authority from the tenderer and proof of identification.

21 The contract is not transferable.

22 TERMINATION

NHSRCL may terminate, by not less than 7 (seven) days' written notice of termination to the bidder, to be given after the occurrence of any of the events as specified below:

- a. If the bidder commits breach of contract or do not remedy/rectify a failure in the performance of their obligations under the Contract.
- b. If the bidder become insolvent or bankrupt.
- c. If the bidder is unable to perform the desired services for a period of not less than fifteen (15) days, or
- d. If the NHSRCL, in its sole discretion, decided to terminate the Contract at any stage.
- e. In the event of a report of unsatisfactory service from the concerned field functionaries, after taking into consideration any other fact as may be relevant on a case to case basis.
- f. In the event of violation of any of the terms & conditions of Contract by the agency, the Performance Security amount/EMD shall stand forfeited in addition to blacklisting of Service Providing Agency for a period of 3 years.
- g. Discrepancy between the tender clauses, if any shall be brought to the notice of NHSRCL & obtain clarifications before submission of bid document. Otherwise if any discrepancy found at later stage decision of NHSRCL shall be final & binding to all bidders & later to responsive bidder.
- h. Interested bidders are instructed to contact NHSRCL office for site visit during working hours.

23 ARBITRATION

- a. All disputes, if any, arising amongst the contracting parties shall be resolved by arbitration. The arbitration shall be conducted in English language and the venue of the arbitration shall be in Delhi.

Seal & Signature of Tenderer

14

Dy. Chief Project Manager Vadodara
उप मुख्य परियोजना प्रबंधक-सिविल
National High Speed Rail Corporation Ltd.
राष्ट्रीय उच्च गति रेल कॉर्पोरेशन लिमिटेड
वडोदरा / Vadodara



Tender Notice No. NHSRCL/Vadodara/Plumbing Utilities/2019-20/03

Appointment of consultant for specialized work of Consultancy for shifting, temporary operation & reinstating various pipelines between Jetalpur Bridge (Ch396.582) to Pandya Bridge (Ch398.430) on proposed High-Speed Railway alignment in Vadodara Station area.

- b. The sole arbitrator will be appointed by the Managing Director, NHSRCL, New Delhi, whose decision in this regard will be final & binding.

24 JURISDICTION

The parties hereby irrevocably consent to the sole jurisdiction of the Courts in Gujarat only in connection with any actions or proceedings arising out of or in relation to this tender.

End of Part II

Dy. Chief Project Manager-Civil
उप मुख्य परियोजना प्रबंधक-सिविल
National High Speed Rail Corporation Ltd.
राष्ट्रीय उच्च गति रेल निगम लिमिटेड
वडादरा / Vadodara



Tender Notice No. NHSRCL/Vadodara/Plumbing Utilities/2019-20/03

Appointment of consultant for specialized work of Consultancy for shifting, temporary operation & reinstating various pipelines between Jetalpur Bridge (Ch396.582) to Pandya Bridge (Ch398.430) on proposed High-Speed Railway alignment in Vadodara Station area.

Part - III
Format for Submission of Information

Name of Work: Bid for selection of Consultant for Detailed Design Preparation for Shifting/Diverting Existing Plumbing Utilities including supervision of execution.

A. Service Providing Agency's Profile

Sl No.	Particulars	Details to be provided by the applicant
1	Name of Bidding Agency (Attach attested copy of certificate of registration)	
2	Name of proprietor / Director of Agency	
3	Full Address of Regd. Office	
	Telephone No.	
	FAX No.	
	E-Mail ID	
	Website	
4	Mobile No. of Proprietor / Director	
	Full Address of Operating / Branch Office	
	Telephone No.	
	FAX No.	
5	E-Mail ID	
	Website	
5	Banker of Institute / Organization with full address (Attach attested / certified copy of Statement of Account for the last three years); Telephone Number of Banker	
6	PAN / GIR No. (Attach attested copy)	
7	Service Tax Registration No. (Attach attested copy)	
8	Income Tax return for last three Financial Years (Attach attested copy)	
9	Service Tax return for last three Financial Years (Attach attested copy)	
10	Financial turnover of Tendering agency / Organization for the last, three Financial Years (Attach Auditor's certified Annual Turnover Certificate)	Financial Year Amount (Rs. In Lakh) 2015 -16 2016-17 2017-18

B. Agency's Experience for last ten years (2011-2018)

- Experience of working in providing services of Designing & Supervision of sewerage, drainage & plumbing system to Govt. or any other organization in India.

(Please provide details of such assignments; Add more rows, if required)

Seal & Signature of Tenderer

16

NHSRCL-Vadodara
Chief Project Engineer
मुख्य परियोजना प्रबंधक-सिविल
National High Speed Rail Corporation Ltd.
राष्ट्रीय उच्च गति रेल कॉर्पोरेशन लिमिटेड
वडोदरा / Vadodara



Tender Notice No. NHSRCL/Vadodara/Plumbing Utilities/2019-20/03

Appointment of consultant for specialized work of Consultancy for shifting, temporary operation & reinstating various pipelines between Jetolpur Bridge (Ch396.582) to Pandya Bridge (Ch398.430) on proposed High-Speed Railway alignment in Vadodara Station area.

Sl No.	Name of Projects Completed	Services provided	Year	Client & Location	Duration of Assignment	Value of Contract (Rs. In Lakhs)

2. Experience in providing services of Consultancy or Development & Designing of sewage, drainage & plumbing system to Govt. or any other organization in India.

(Please provide details of such assignments; Add more rows, if required)

Sl No.	Name of the Client	Nature of the assignment (providing consultancy services& supervision of Sewage, Drainage works)	Location and Coverage / Duration of Assignment (in month)	Works completed or in progress - design, execution stage	Value of Contract (Rs. In Lakhs)

3. Provide details of employees trained and experienced in Detailed Design Preparation for Sewerage, Drainage & other plumbing utilities system complete including Live/Working Lines Shifting/Diverting Plumbing Utilities (Add more rows, if required)

(Add more rows, if required)

Sl No.	Name of Employees with designation	Qualification & Position held	Trained in Design of Drainage, Sewerage works	Working in the Agency Since (in years and months)	Name of assignment handled	Mobile No.

Seal & Signature of Tenderer

Dy. Chief Project Manager-Civil
 उप मुख्य परियोजना प्रबंधक-सिविल
 NHSRCL-Vadodara
 National High Speed Rail Corporation Ltd.
 राष्ट्रीय उच्च गति रेल निगम लिमिटेड
 वडोदरा / Vadodara



Tender Notice No. NHSRCL/Vadodara/Plumbing Utilities/2019-20/03

Appointment of consultant for specialized work of Consultancy for shifting, temporary operation & reinstating various pipelines between Jetalpur Bridge (Ch396.582) to Pandya Bridge (Ch398.430) on proposed High-Speed Railway alignment in Vadodara Station area.

Provide details of employees currently engaged in the Agency for Supervision of Sewerage, Drainage & other plumbing utilities system complete including Live/Working lines Shifting/Diverting Plumbing Utilities (Add more rows, if required) (Add more rows, if required)

Sl No.	Name of Employees with designation	Qualification & Position held	Trained in Execution of Drainage, Sewerage works	Working in the Agency Since (in years and months)	Name of assignment handled	Mobile No.

4. Any other documents/certificates asked anywhere in the tender documents in addition to above mentioned documents.

Date:
Place:

Signature of authorized person
Name:
Seal:

End of Part III

Dy. Chief Project Manager-Civil
राष्ट्रीय उच्च गति रेल निगम लिमिटेड
National High Speed Rail Corporation Ltd.
वडोदरा / Vadodara

Seal & Signature of Tenderer



Tender Notice No. NHSRCL/Vadodara/Plumbing Utilities/2019-20/03

Appointment of consultant for specialized work of Consultancy for shifting, temporary operation & reinstating various pipelines between Jetalpur Bridge (Ch396.582) to Pandya Bridge (Ch398.430) on proposed High-Speed Railway alignment in Vadodara Station area.

Part IV

Estimated Cost of work:

The estimated cost of works of providing specialized consultancy of underground plumbing utilities for location between Jetalpur Bridge(Ch396.582) to Pandya Bridge(Ch398.430) including Detailed Design scheme preparation for Shifting(temporarily, permanently)/Diverting existing underground plumbing utilities including preparation of detailed cost estimate, BOQ, Specifications, GFC drawings, approvals from various stakeholders, supervision of works etc. complete as infringing in the foundation works of construction of HSR Corridor is Rs. 43,00,000.00 only.

End of Part IV

Part V

Tender Drawings:

Tentative drawings of the above-mentioned location's plumbing utilities are enclosed with the tender. These drawings are indicative only for references and the tenderers are advised to visit the locations for proper assessment before submitting the tender offer.

1. Tentative Existing Plumbing Utilities including Pumping Station -Charted
2. Tentative Diversion plan for traffic during construction.

End of Part V

Dy. Chief Engineer, Manager, Civil
National High Speed Rail Corporation Ltd.
Vadodara
431431, Vadodara

Seal & Signature of Tenderer

19

NHSRCL-Vadodara



Tender Notice No. NHSRCL/Vadodara/Plumbing Utilities/2019-20/03

Appointment of consultant for specialized work of Consultancy for shifting, temporary operation & reinstating various pipelines between Jetalpur Bridge (Ch396.582) to Pandya Bridge (Ch398.430) on proposed High-Speed Railway alignment in Vadodara Station area.

Part VI

OFFER SHEET

Name of the work -: Specialized work of Consultancy for shifting, temporary operation & reinstating various pipelines between Jetalpur Bridge (Ch396.582) to Pandya Bridge(Ch398.430) on proposed High Speed Railway alignment in Vadodara Station area as detailed in the scope of works.

Item No.	Estimated Cost of consultancy works in Rs. Ps.	RATE QUOTED BY THE TENDERER	
		In Figures	In Words
1.	43,00,000.00	%age Above/Below/At par*	%age Above/Below/At par*

* Strike whichever is not applicable (above/below/At par)

NOTES: -

1. If the tenderer is not clearly mentioning that the rates "Above, Below or At par", or kept blank, then the rates shall be considered as ambiguous. And the offer will be summarily rejected.
2. In case of any discrepancy in the quoted rates in between the rates quoted in words and figures, the rates quoted on lower side shall be considered.
3. The above rates are excluding GST which will be reimbursed on submission of relevant documents.

Signature of Tenderer

Date: - _____

End of Part VI

Dy. Chief Project Manager-Civil
उप मुख्य परियोजना प्रबंधक-सिविल
National High Speed Rail Corporation Ltd.
राष्ट्रीय उच्च गति रेल निगम लिमिटेड
वडोदरा / Vadodara

Seal & Signature of Tenderer



Tender Notice No. NHSRCL/Vadodara/Plumbing Utilities/2019-20/03
Appointment of consultant for specialized work of Consultancy for shifting, temporary operation & reinstating various pipelines between Jetalpur Bridge (Ch396.582) to Pandya Bridge (Ch398.430) on proposed High-Speed Railway alignment in Vadodara Station area.

Part VII

DECLARATION

1. I, _____ son/ daughter/ wife of Shri _____ proprietor/ Director/ authorized signatory of the agency mentioned above, is competent to sign this declaration and execute this tender;
2. I have carefully read and understood all the terms and conditions of the tender and undertake to abide by them;
3. The information/documents furnished along with the above application are true and authentic to the best of my knowledge and belief. I/we, am/are well aware of the fact that furnishing of any false information/ fabricated documents would lead to rejection of my/our tender at any stage besides liabilities towards prosecution under appropriate law and forfeiture of EMD and Performance Security.

Date:
Place:

Signature of authorized person
Name:
Seal:

End of Part VII

Dy. Chief Project Manager-Civil
उप मुख्य परियोजना प्रबंधक-सिविल
National High Speed Rail Corporation Ltd.
राष्ट्रीय उच्च गति रेल निगम लिमिटेड
वडावरा / Vadodara

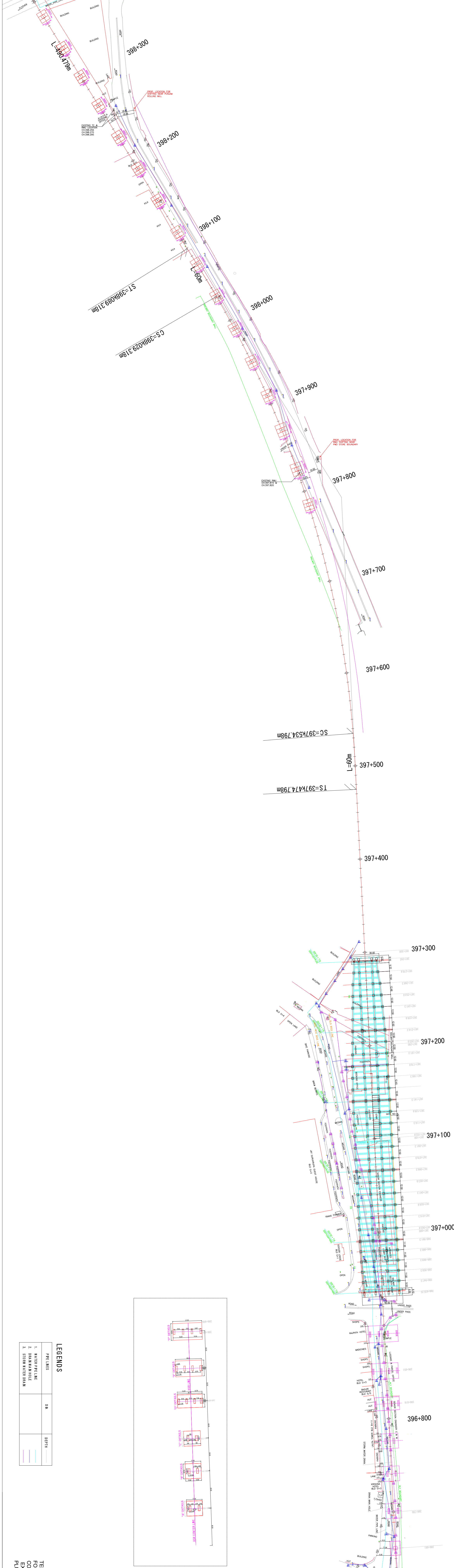

000 WOOD ROAD (131) 131 131 131
 398+400
 398+300
 398+200
 398+100
 000+800
 397+900
 397+800
 397+700
 397+600
 397+500
 397+400
 397+300
 397+200
 397+100
 397+000
 000
 396+800

SC=397K534.798m
 TS=397K474.798m
 UG9=1

ST=396K623.265m
 CS=396K583.265m

ST=398K089.318m
 CS=398K079.318m

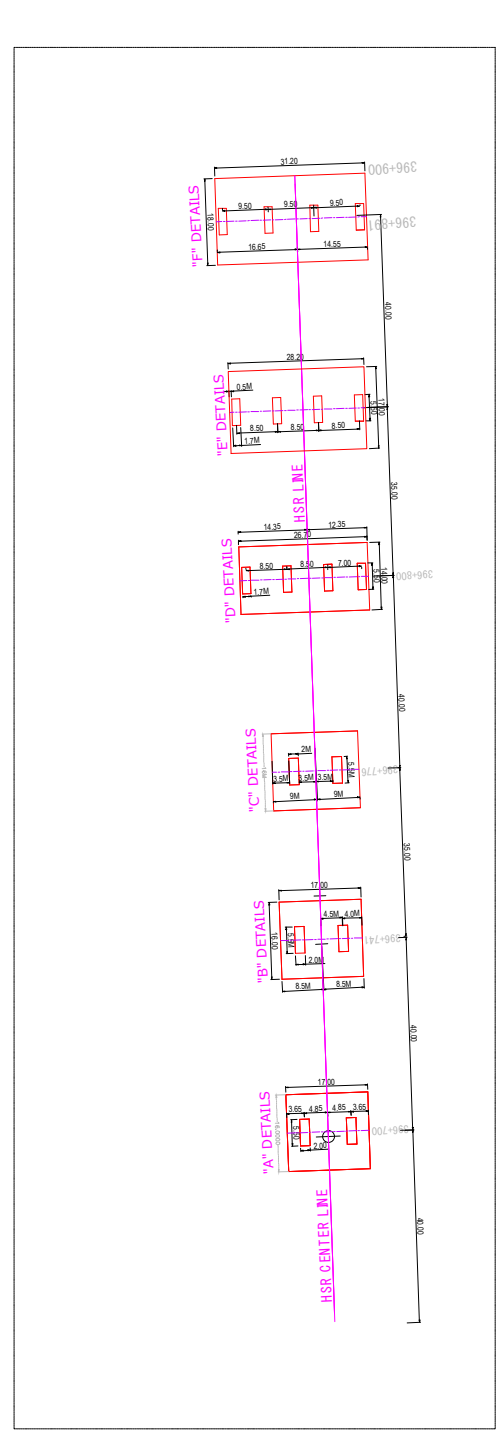

LEGENDS

PRE LINES	OR	DEPTH
1. WATER PIPE LINE		
2. DRAINAGE		
3. STORM WATER DRAIN		

TENDER DRAWING NO-1
 FOR APPOINTMENT OF
 CONSULTANT TENTATIVE
 EXISTING UNDERGROUND
 PLUMBING UTILITIES

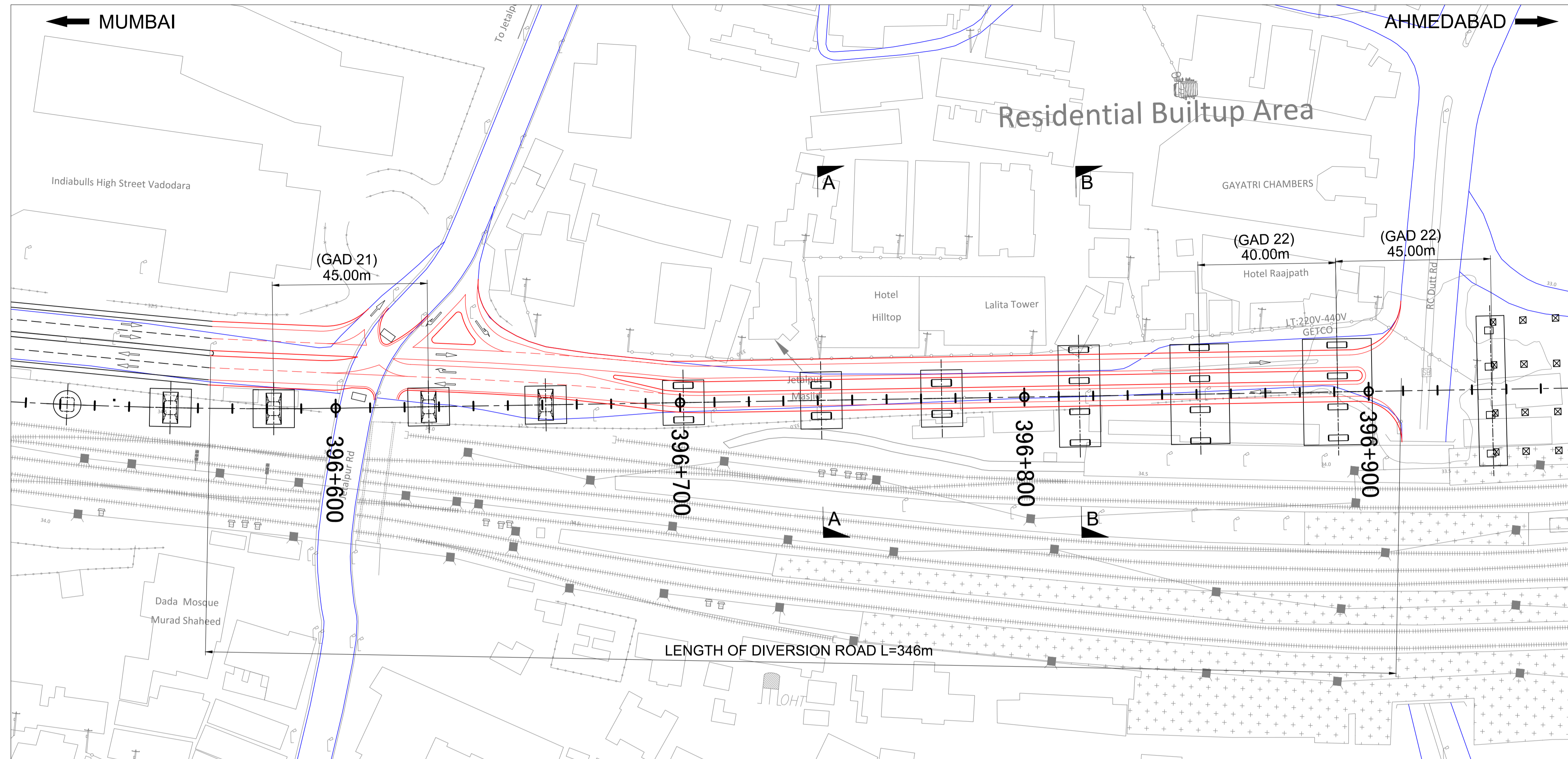

PLAN
SCALE 1:800

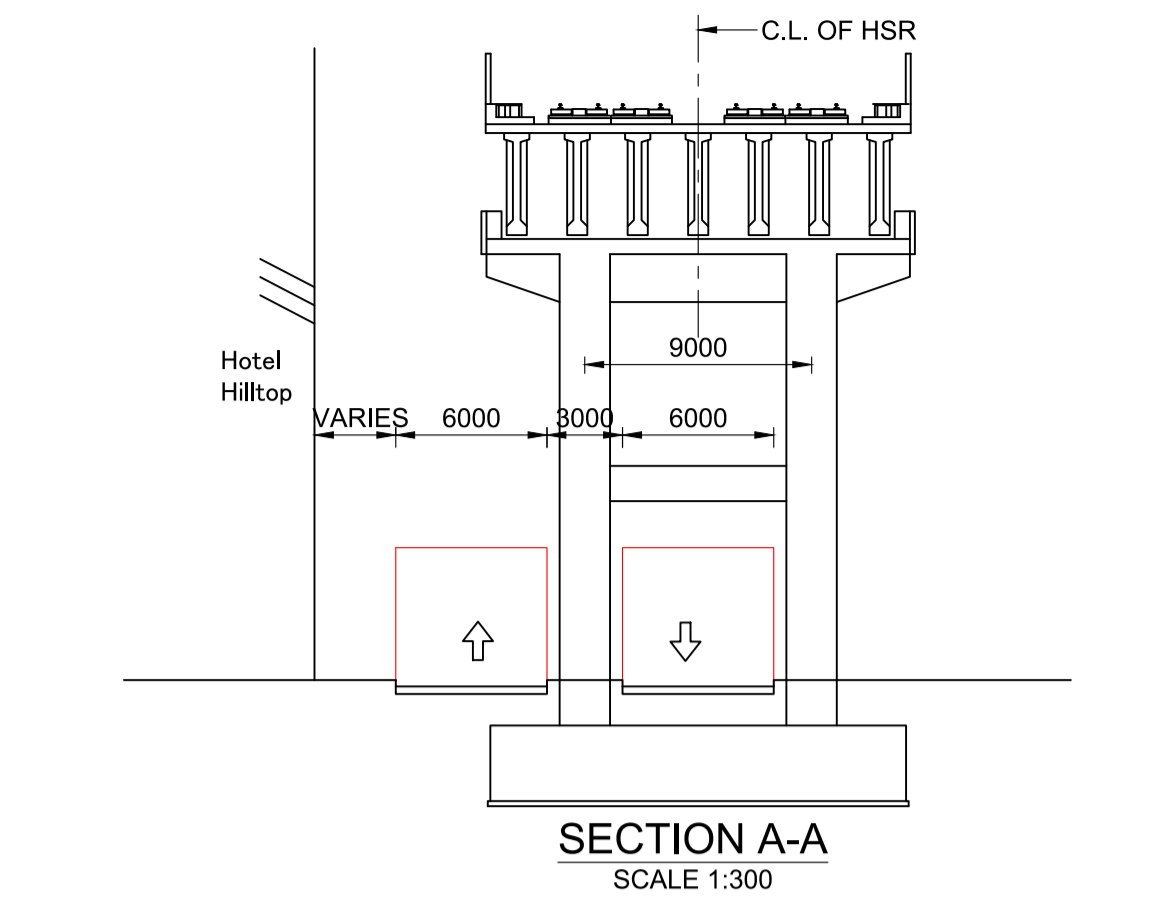

SECTION A-A
SCALE 1:300

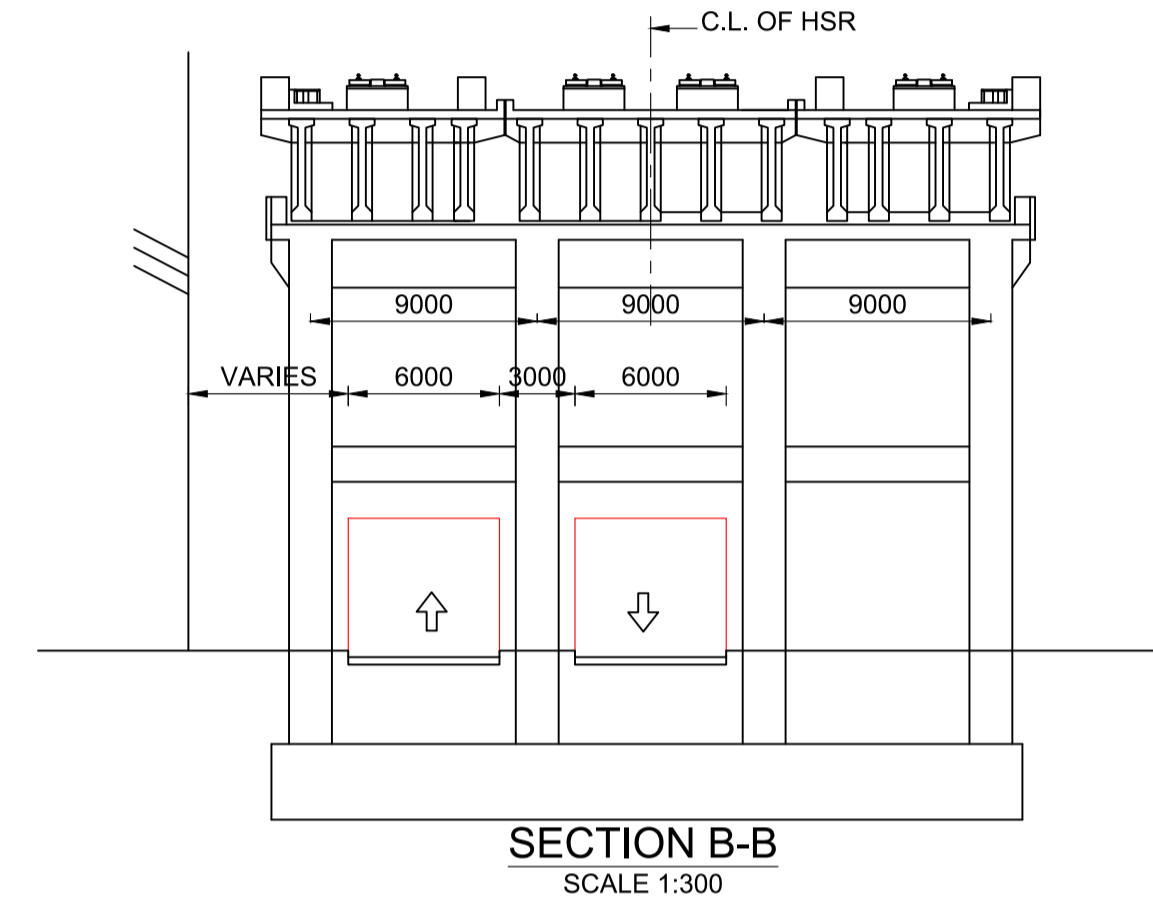

SECTION B-B
SCALE 1:300

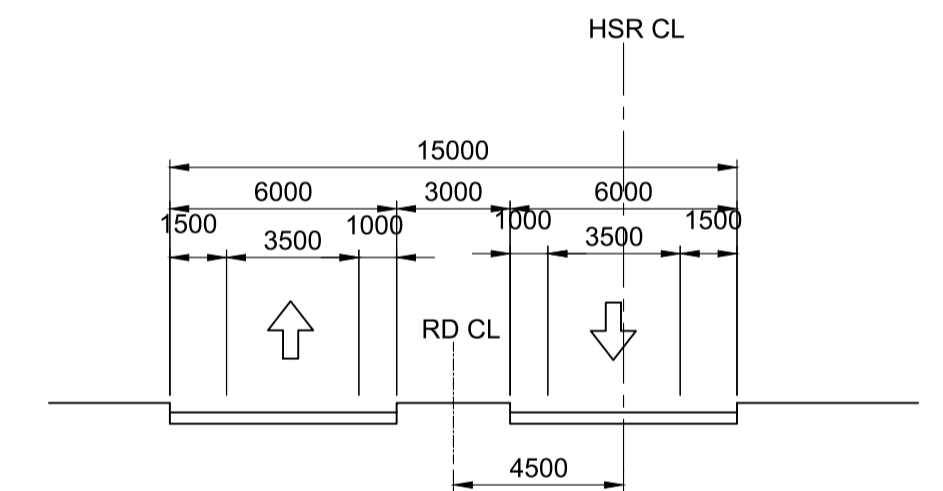

ROAD CROSS SECTION

LEGENDS:

PROPOSED ROAD	—
EXISTING ROAD	—

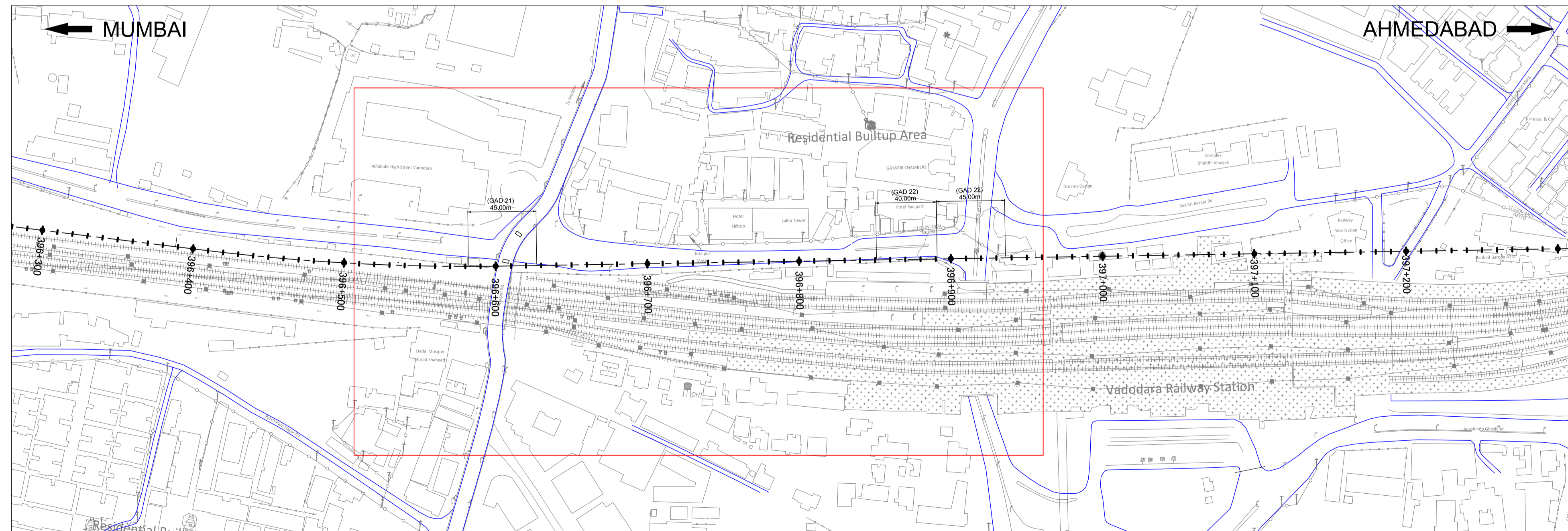

KEY PLAN
SCALE NTS

**TENDER DRAWING NO:2
FOR APPOINTMENT OF
CONSULTANT TENTATIVE
TRAFFIC DIVERSION PLAN
CH: 396+600 TO 396+900**

FOR APPROVAL

(NO OBJECTION)

ADOPTED BY: **NHSRCL**

PREPARED & APPROVED BY: **JIC**

TITLE: **PROPOSED ROAD DIVERSION PLAN AT KM 396.470 AND 396.653 AND 396.698**

SCALE: AS SHOWN SHEET No.: 1 OF 1
DRAWING No: JIC/NHSRCL/MAHSR/BR/1855-2 & 1857 & 1858 DATE: JUNE 2018

REV.	PARTICULARS	DATE	CONSULTANT	NHSRCL	PROJECT:

OWNER:
NHSRCL
NATIONAL HIGH SPEED RAIL CORPORATION LTD.

MUMBAI-AHMEDABAD HIGH SPEED RAIL PROJECT

CONSULTANT:
JIC
JAPAN INTERNATIONAL CONSULTANTS FOR TRANSPORTATION